

Recommended P.C. Board Layout

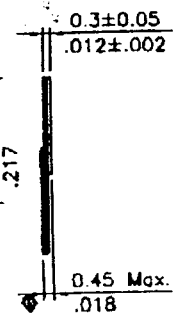
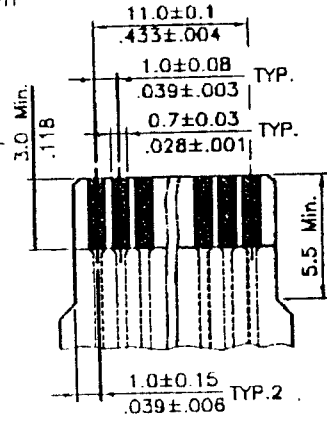
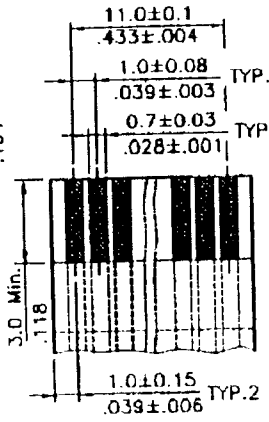
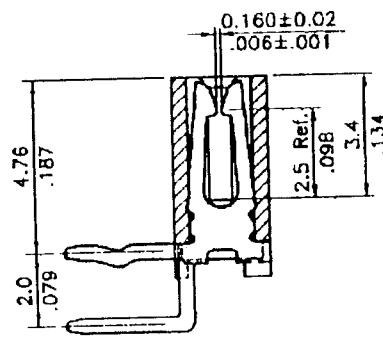
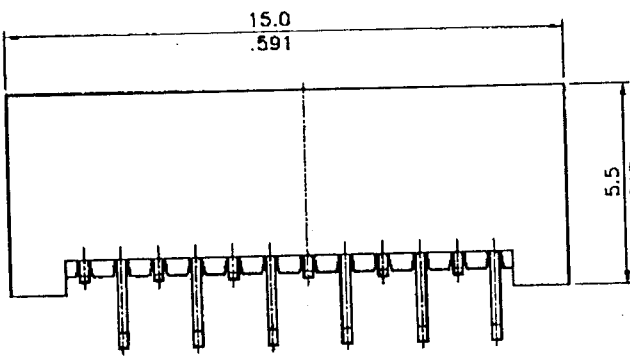

Accommodated FFC

Accommodated FPC

**MATERIAL:**  
 Insulator: Glass Filled Nylon 6T UL 94V-0  
 Contacts: Phosphor bronze with Tin plated  
**PART NO.**

831 A - XX N I R O 1 X 7  
 1 2 3 4 5 6 7 8 9 10

- 1.SERIES NO.  
831
- 2.TYPE.  
A=STANDARD
- 3.CONTACT NUMBER.
- 4.CONTACT TYPE.  
N=NON ZIF
- 5.CONTACT PLATING.  
T=Tin plated over Nickel
- 6.MOUNTING TYPE.  
R=90°
- 7.PARTS DIMENSION:  
0=PITCH:1.00mm
- 8.TYPE OPTION:  
1=DUAL CONTACT
- 9.PACKING TYPE:  
0=Tube or Tray(standard)  
1=Tape & Reel
- 10.INSULATOR LCOLOR  
7=Brown



UNLESS OTHERWISE SPECIFIED TOLERANCE	
ANG.	±1°
0	±0.15
.00	±0.10
.000	±0.05

**OXOC**  
**CHANT SINCERE CO., LTD**  
 TEL:886-02-86471251 FAX:886-02-86472962

SCALE: AS SHOWN	UNIT: mm
DRAWN PEARL	06/18/03
CHECKED Joe	06/24/03
APPROVED [Signature]	06/24/03
SIZE A4	REV. A

DRAWN NAME: FPC (1.00mm) ASS'Y
PRODUCT NO. 831A-XXNTR01X7
FILE NAME: 831A-XXNTR01X7(23)

A	DRA-0306026(Rita)	DESCRIPTION	DATE
REV.			

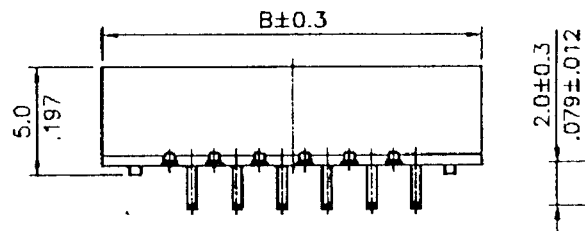
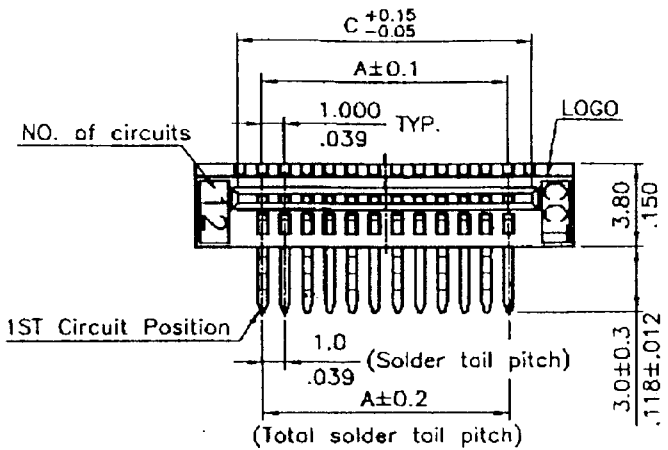

A = 1.00 \* No. of Spaces  
 B = A + 6.0  
 C = A + 2.2  
 \* Available in 4 through 32 circuits

- MATERIAL:**  
 Insulator: Nylon 6T UL 94V-0  
 Contacts: Phosphor bronze  
**PART NO.**  
 831 A - XX N I R 0 3 X 3  
 1 2 3 4 5 6 7 8 9 10
- SERIES NO.  
831
  - TYPE.  
A=STANDARD
  - CONTACT NUMBER.
  - CONTACT TYPE.  
N=NON ZIF
  - CONTACT PLATING.  
T=Tin plated over Nickel
  - MOUNTING TYPE.  
R=90°
  - PARTS DIMENSION:  
0=PITCH:1.00mm
  - TYPE OPTION:  
3=Down side contact
  - PACKING TYPE:  
0=Tube or Tray(standard)  
1=Tape & Reel
  - INSULATOR LCOLOR  
3=Black

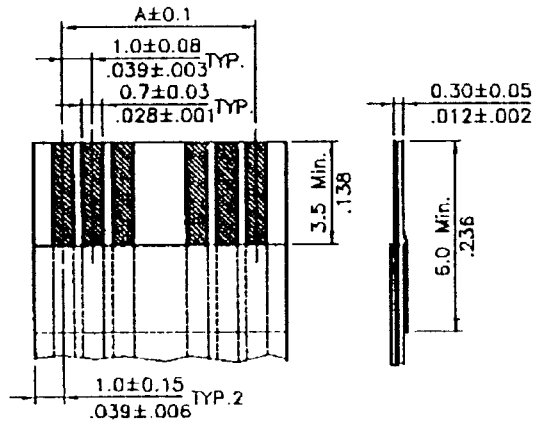
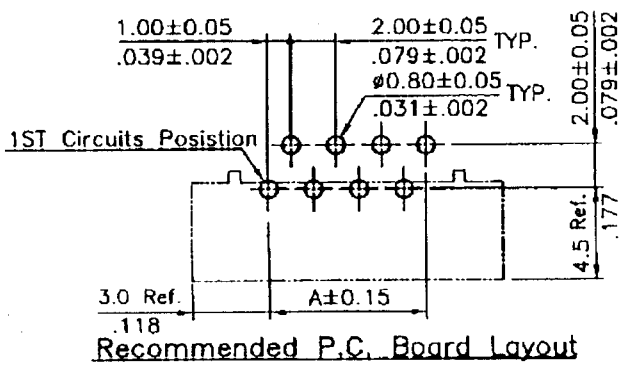
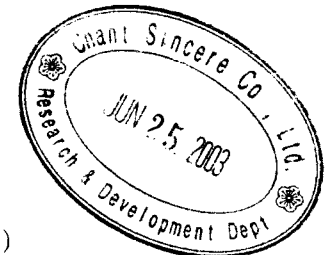

\* ACCOMMODATED FPC

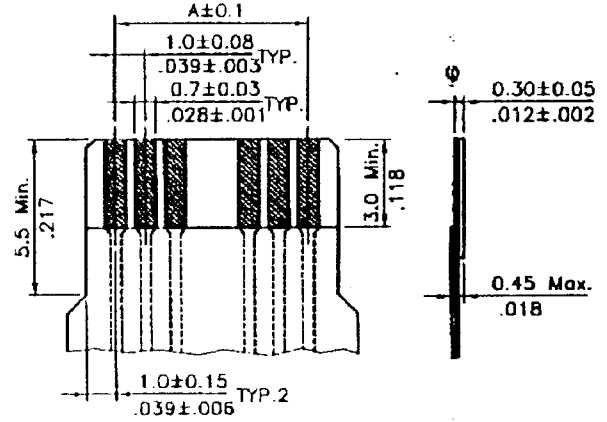

\* ACCOMMODATED FPC

UNLESS OTHERWISE SPECIFIED TOLERANCE			
ANG.	±1°		
0	±0.15	<b>CHANT SINCERE CO., LTD</b> TEL:886-02-86471251 FAX:886-02-86472962	
.00	±0.10		
.000	±0.05		
SCALE:	AS SHOWN	UNIT:	mm
DRAWN	PEARL	DATE	06/18/03
CHECKED	Joe	DATE	06/24/03
APPROVED	[Signature]	DATE	06/18/03
SIZE	A4	REV	A
DRAWN NAME:		FPC	
CHECKED NAME:		(1.00mm) ASS'Y	
DATE		PRODUCT NO: 831A-XXNTR03X3	
FILE NAME:		831A-XXNTR03X3(23)	

REV.	DESCRIPTION	DATE
A	DRA-0306026(Rita)	06/18/03

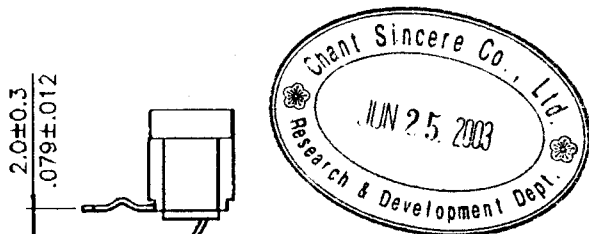
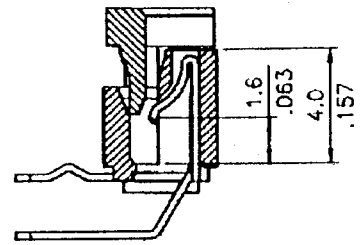
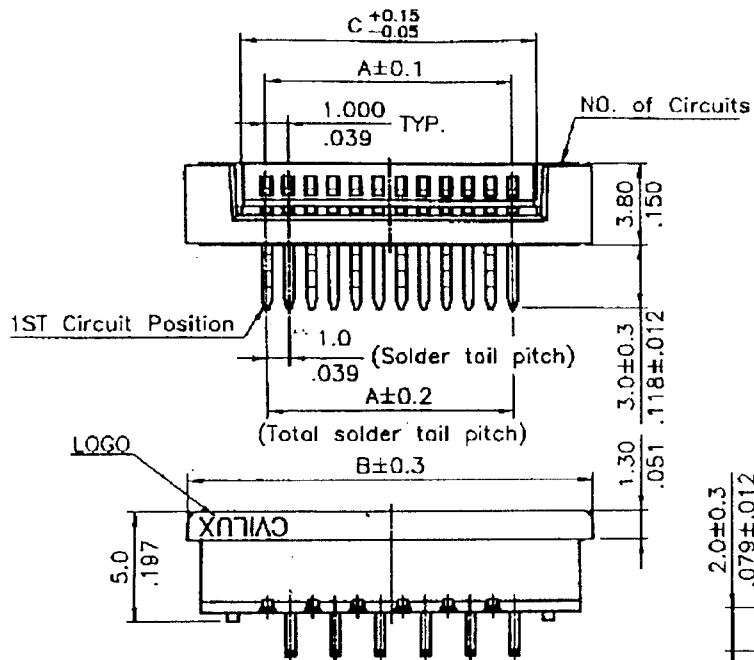

A = 1.00 \* No. of Spaces  
 B = A + 7.2  
 C = A + 2.2  
 \* Available in 4 through 32 circuits

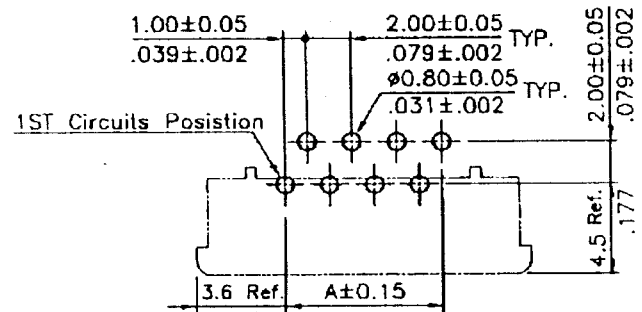

**Recommended P.C. Board Layout**

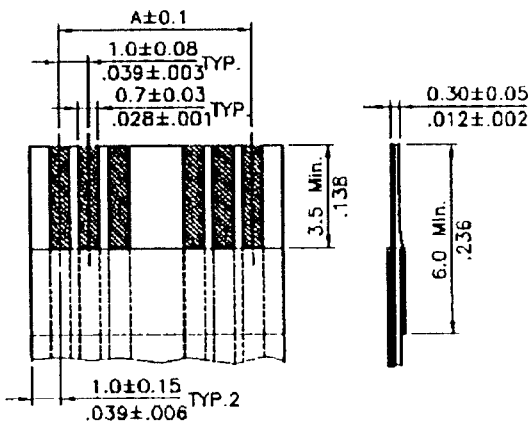
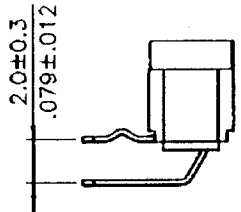

**\* ACCOMMODATED FPC**

**MATERIAL:**  
 Insulator: Nylon 6T UL 94V-0  
 Slider: Nylon 6T UL 94V-0, Color Brown  
 Contacts: Phosphor bronze  
**PART NO.**

831 A - XX P I R O 2 X 5  
 1 2 3 4 5 6 7 8 9 10

- 1.SERIES NO.  
831
- 2.TYPE.  
A=STANDARD
- 3.CONTACT NUMBER.
- 4.CONTACT TYPE.  
P=ZIF
- 5.CONTACT PLATING.  
T=Tin plated over Nickel
- 6.MOUNTING TYPE.  
R=90°
- 7.PARTS DIMENSION:  
0=PITCH:1.00mm
- 8.TYPE OPTION:  
2=Up side contact
- 9.PACKING TYPE:  
0=Tube or Tray(standard)  
1=Tape & Reel
- 10.INSULATOR LCOLOR  
5=BEIGE

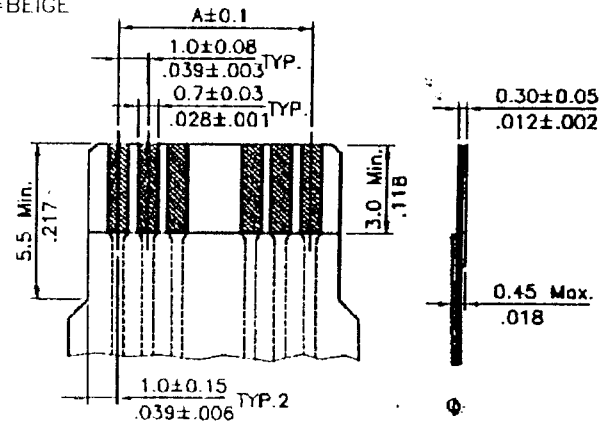

**\* ACCOMMODATED FPC**

UNLESS OTHERWISE SPECIFIED TOLERANCE		 <b>CHANT SINCERE CO.,LTD</b> TEL:886-02-86471251 FAX:886-02-86472962	
SCALE: AS SHOWN	UNIT: mm		
DRAWN PEARL	06/18/03	DRAWN NAME: FPC (1.00mm) ASS'Y	
CHECKED Joe	06/24/03	PRODUCT NO: 831A-XXPTR02X5	
APPROVED	06/24/03	FILE NAME: 831A-XXPTR02X5(23)	
DATE		SIZE A4	REV. A

REV.	DESCRIPTION	DATE
A	DRA-0306026(Rita)	06/18/03

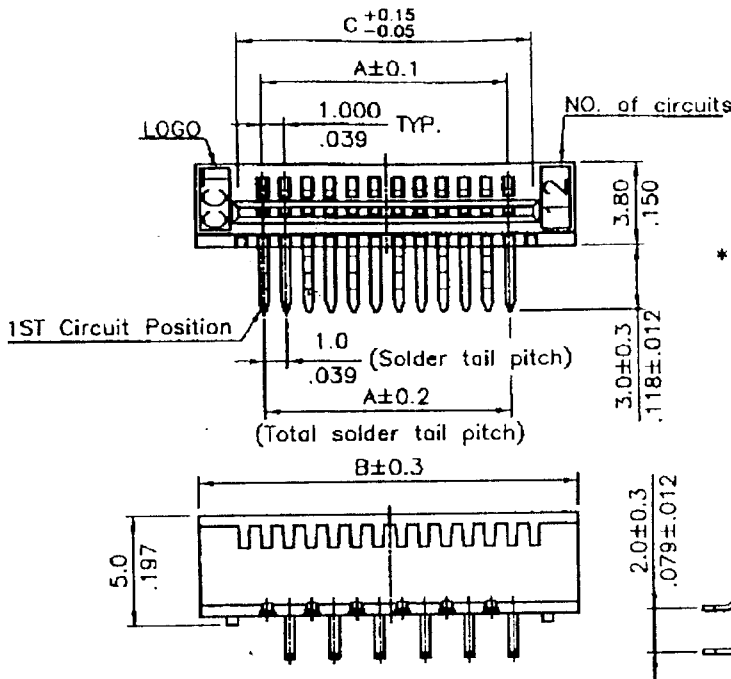

A = 1.00 \* No. of Spaces  
 B = A + 6.0  
 C = A + 2.2  
 \* Available in 4 through 32 circuits



- MATERIAL:**  
 Insulator: Nylon 6T UL 94V-0  
 Contacts: Phosphor bronze  
**PART NO.**  
 831 A - XX N I R 0 2 X 3  
 1 2 3 4 5 6 7 8 9 10
- SERIES NO. 831
  - TYPE. A=STANDARD
  - CONTACT NUMBER.
  - CONTACT TYPE. N=NON ZIF
  - CONTACT PLATING. T=Tin plated over Nickel
  - MOUNTING TYPE. R=90°
  - PARTS DIMENSION: 0=PITCH:1.00mm
  - TYPE OPTION: 2=Up side contact
  - PACKING TYPE: 0=Tube or Tray(standard)  
1=Tape & Reel
  - INSULATOR LCOLOR 3=Black

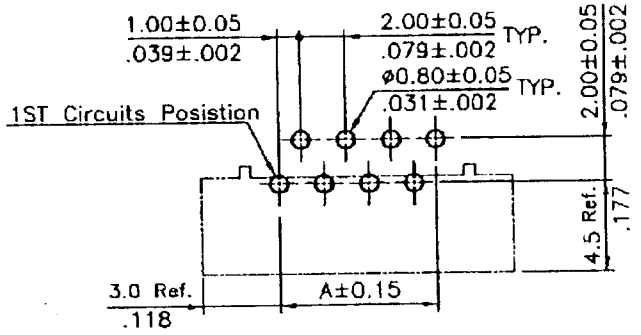

**Recommended P.C. Board Layout**

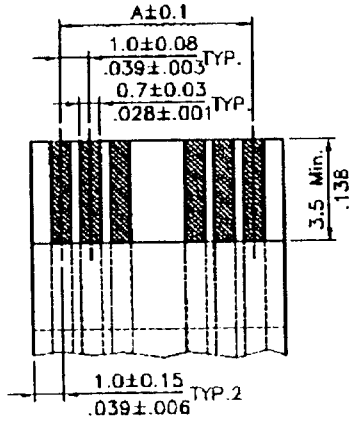

**\* ACCOMMODATED FPC**

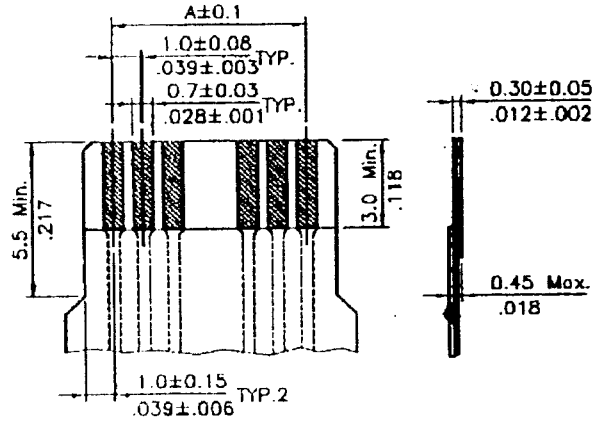

**\* ACCOMMODATED FPC**

UNLESS OTHERWISE SPECIFIED TOLERANCE		 <b>CHANT SINCERE CO., LTD</b> TEL:886-02-86471251 FAX:886-02-86472962	
ANG.	±1°		
.0	±0.15		
.00	±0.10		
SCALE:	AS SHOWED	UNIT:	mm
DRAWN	PEARL	DATE	06/18/03
CHECKED	Joe	DATE	06/24/03
APPROVED	簡雨晴	DATE	06/24/03
REV.		SIZE	A4
		REV.	A
DRAWN NAME:		FPC (1.00mm) ASS'Y	
PRODUCT NO.		831A-XXNTR02X3	
FILE NAME:		831A-XXNTR02X3(23)	

REV.	DESCRIPTION	DATE
A	DRA-0306026(Rita)	06/18/03

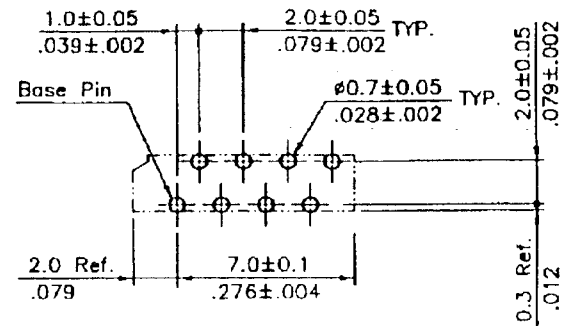
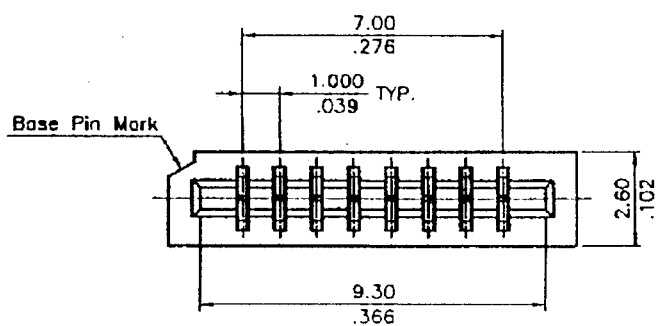

Recommended P.C. Board Layout

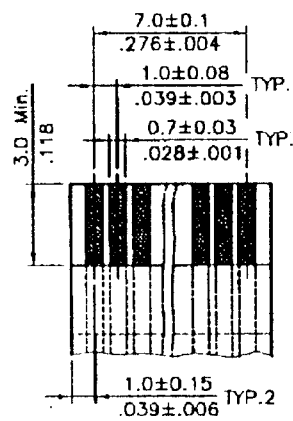
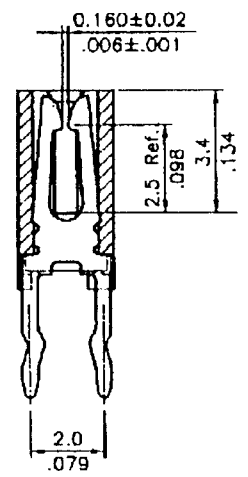
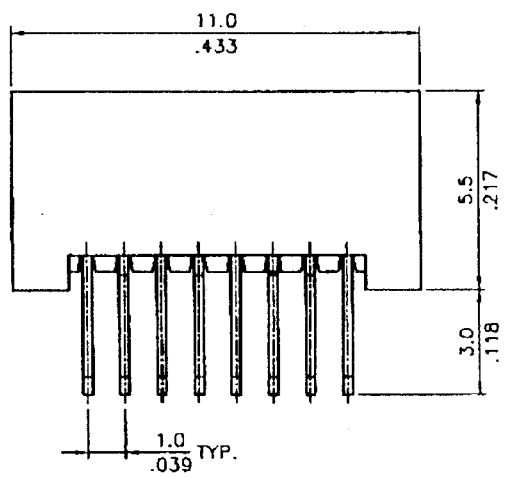

Accommodated FFC

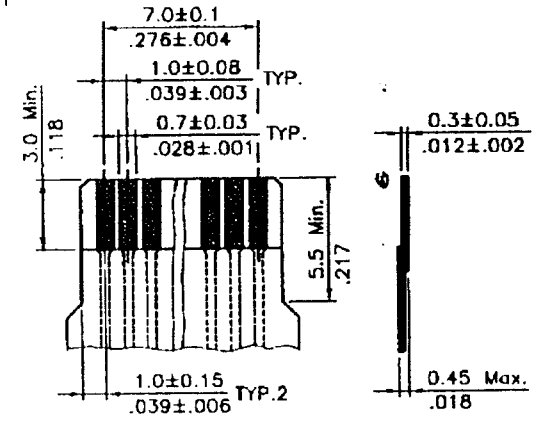

Accommodated FPC

MATERIAL:  
 Insulator: Glass Filled Nylon 6T UL 94V-0  
 Contacts: Phosphor bronze with Tin plated  
 PART NO.

831 A - XX N I S O 1 X 7  
 1 2 3 4 5 6 7 8 9 10

- 1.SERIES NO.  
831
- 2.TYPE.  
A=STANDARD
- 3.CONTACT NUMBER.
- 4.CONTACT TYPE.  
N=NON ZIF
- 5.CONTACT PLATING.  
T=Tin plated over Nickel
- 6.MOUNTING TYPE.  
S=180°
- 7.PARTS DIMENSION:  
0=PITCH:1.00mm
- 8.TYPE OPTION:  
1=DUAL CONTACT
- 9.PACKING TYPE:  
0=Tube or Tray(standard)  
1=Tape & Reel
- 10.INSULATOR LCOLOR  
7=Brown



UNLESS OTHERWISE SPECIFIED TOLERANCE  
 ANG. ±1°  
 .0 ±0.15  
 .00 ±0.10  
 .000 ±0.05



CHANT SINCERE CO., LTD  
 TEL:886-02-86471251 FAX:886-02-86472962

SCALE: AS SHOWN UNIT: mm

DRAWN PEARL 06/18/03

DRAWN NAME: FPC

CHECKED Joe 06/24/03

(1.00mm) ASS'Y (STRAIGHT)

APPROVED 06/18/03

PRODUCT NO. 831A-XXNTS01X7

DATE

FILE NAME: 831A-XXNTS01X7(23)

A DRA-0306026(Rita)

REV.	DESCRIPTION	DATE	SIZE	REV.
A		06/18/03	A4	A

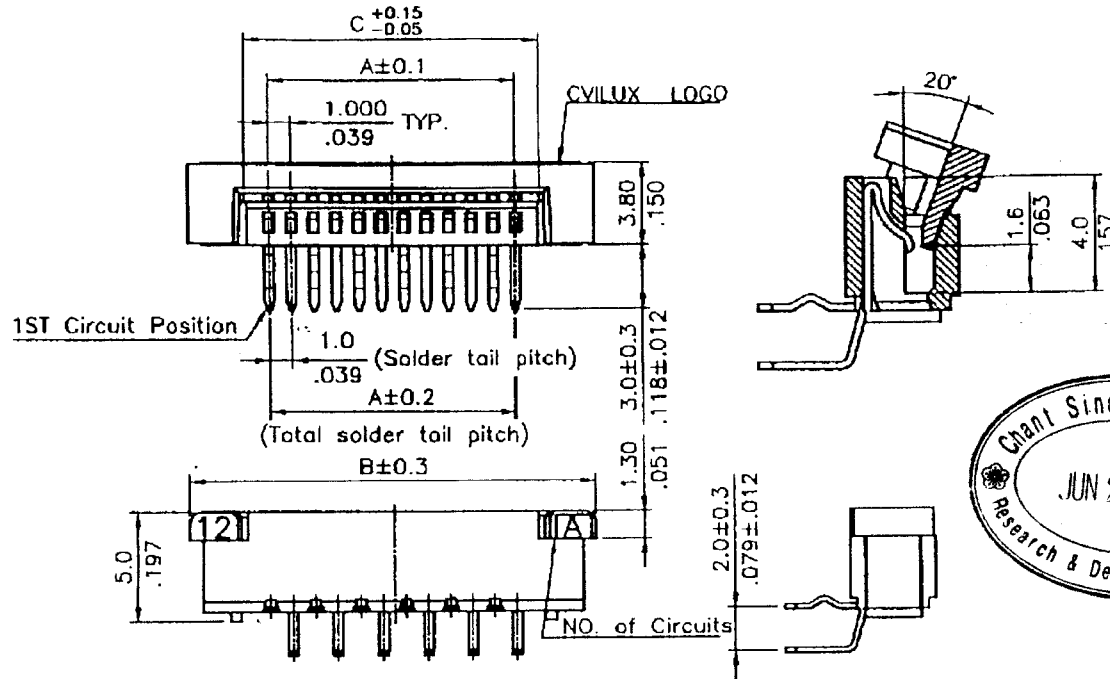

A = 1.00 \* No. of Spaces  
 B = A + 7.2  
 C = A + 2.2

\* Available in 4 through 32 circuits

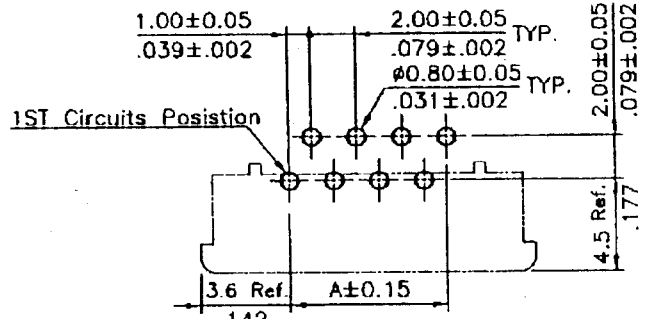

Recommended P.C. Board Layout

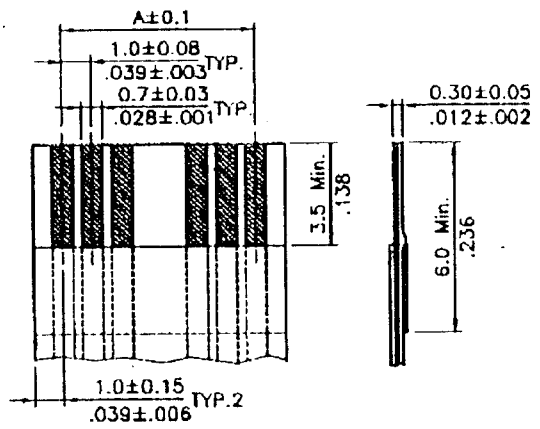

\* ACCOMMODATED FPC

**MATERIAL:**

Insulator: Nylon 6T UL 94V-0  
 Slider: Nylon 6T UL 94V-0, Color Brown  
 Contacts: Phosphor bronze

**PART NO.**

831 A - XX P I R 0 3 X 5  
 1 2 3 4 5 6 7 8 9 10

- 1.SERIES NO.  
831
- 2.TYPE.  
A=STANDARD
- 3.CONTACT NUMBER.
- 4.CONTACT TYPE.  
P=ZIF
- 5.CONTACT PLATING.  
T=Tin plated over Nickel
- 6.MOUNTING TYPE.  
R=90°
- 7.PARTS DIMENSION:  
0=PITCH:1.00mm
- 8.TYPE OPTION:  
3=Down side contact
- 9.PACKING TYPE:  
0=Tube or Tray(standard)  
1=Tape & Reel
- 10.INSULATOR LCOLOR  
5=BEIGE

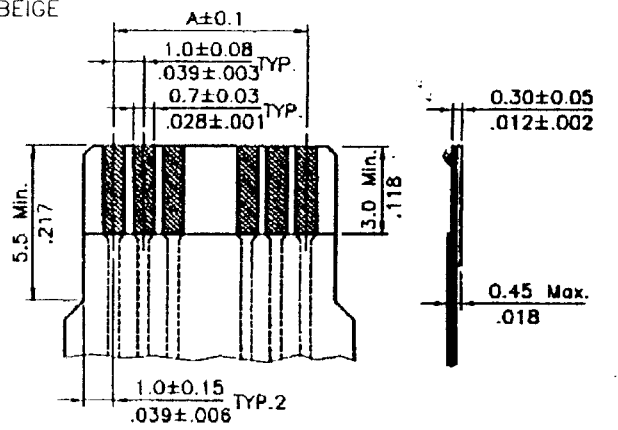

\* ACCOMMODATED FPC

UNLESS OTHERWISE SPECIFIED TOLERANCE			
ANG.	±1°		
.0	±0.15	<b>CHANT SINCERE CO., LTD</b> TEL:886-02-86471251 FAX:886-02-86472962	
.00	±0.10		
.000	±0.05		
SCALE: AS SHOWN UNIT: mm			
DRAWN	PEARL	06/18/03	DRAWN NAME:
CHECKED	Joe	06/24/03	FPC
APPROVED	周雨晴	06/24/03	(1.00mm) ASS'Y
DATE	06/18/03		PRODUCT NO. 831A-XXPTR03X5
SIZE	A4	REV. A	FILE NAME: 831A-XXPTR03X5(23)

REV.	A	DRA-0306026(Rita)	DESCRIPTION	DATE	06/18/03
------	---	-------------------	-------------	------	----------