

MATERIAL:  
 \* INSULATION: GLASS FILLED POLYESTER  
 UL 94-0 COLOR NATURE  
 \* CONTACT: PHOSPHOR BRONZE

PART NO.

831 A - XX P I R 2 Q Q 5  
 1 2 3 4 5 6 7 8 9 10

1.SERIES NO.  
831

2.TYPE.  
A=STANDARD

3.CONTACT NUMBER.  
03-32

4.CONTACT TYPE.  
P= ZIF

5.CONTACT PLATING.  
T=TIN/LEAD

6.MOUNTING TYPE.  
R=RIGHT ANGLE

7.PARTS DIMENSION:  
2=PITCH:1.25mm

8.FILL IT WITH '0'

9.FILL IT WITH '0'

10.INSULATOR LCOLOR  
5=BEIGE

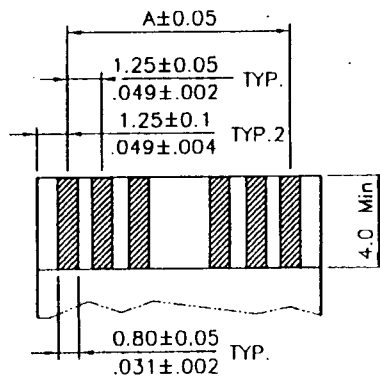
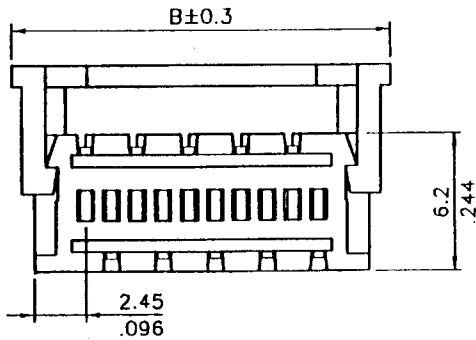
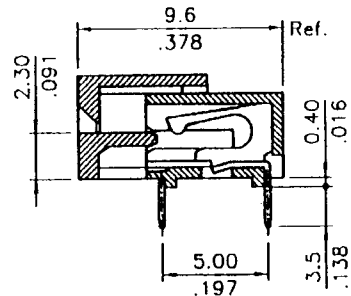
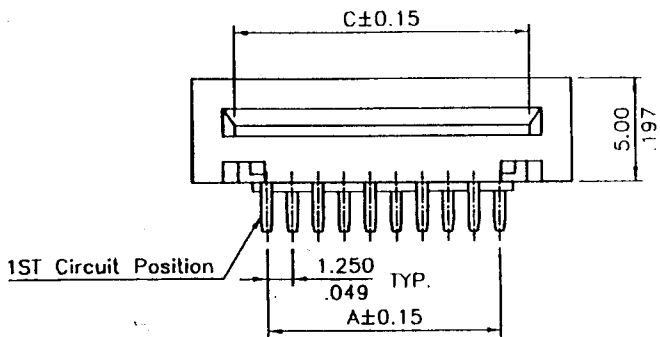

Accommodated FPC/FFC  
 (Thickness: 0.3mm±0.05)

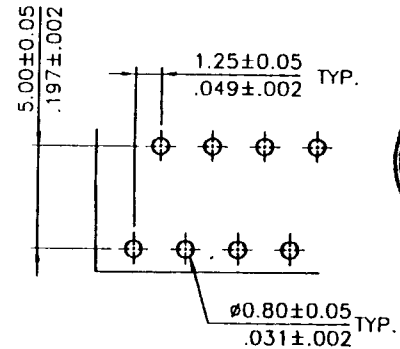

Recommended P.C. Board Layout

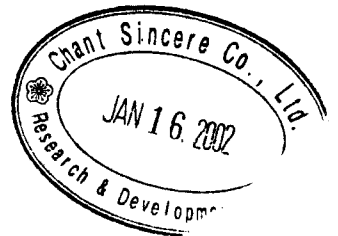

A = 1.25 \* No. of Spaces  
 B = A + 7.1  
 C = A + 2.7  
 \* Available in 3 through 32 circuits

UNLESS OTHERWISE SPECIFIED TOLERANCE	
ANG.	±5°
0.	±0.5
.0	±0.3
.00	±0.2



SCALE: AS SHOWN UNIT: mm

CHANT SINCERE CO., LTD  
 TEL:886-02-86471251 FAX:886-02-86472962

DRAWN JOE 01/10/02

DRAWN NAME:  
FPC (1.25mm) ASS'Y(RIGHT ANGLE)

CHECKED [Signature] 01/11/02

APPROVED [Signature] 01/16/02

PRODUCT NO. 831A-XXPTR2005

A	DRA-0201021(Alex)	01/09/02
REV.	DESCRIPTION	DATE

SIZE A4 REV. A

FILE NAME: 831A-XXPTR2005(23)

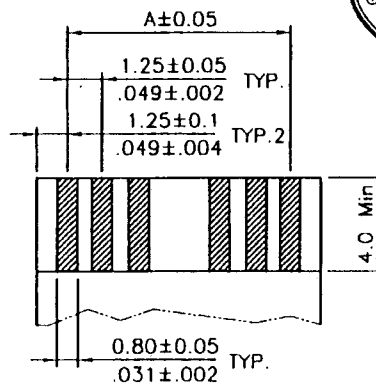
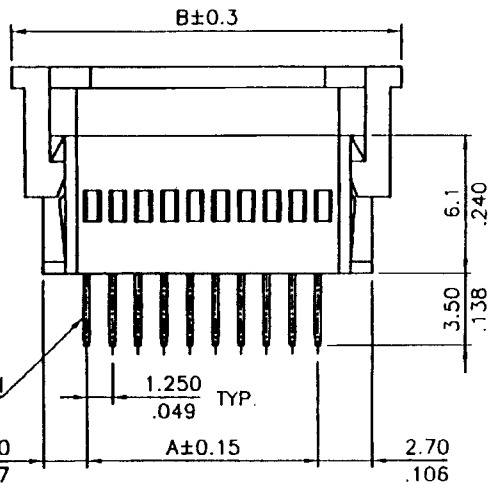
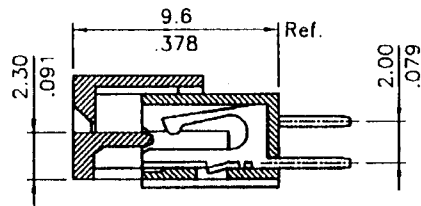
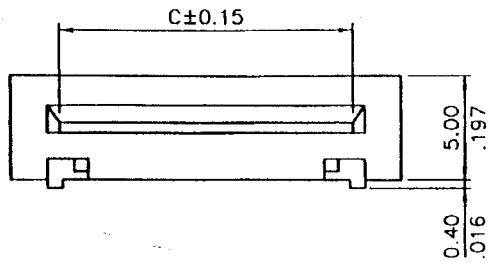

Accommodated FPC/FFC  
(Thickness: 0.3mm±0.05)

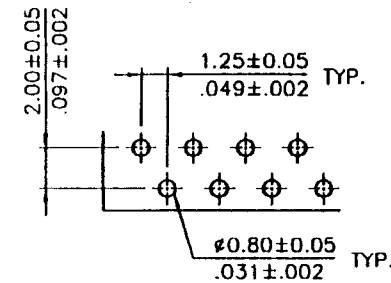

Recommended P.C. Board Layout

MATERIAL:  
\* INSULATION: GLASS FILLED POLYESTER  
UL 94-0 COLOR NATURE  
\* CONTACT: PHOSPHOR BRONZE

PART NO.

831 A - XX P I S 2 0 0 5  
1 2 3 4 5 6 7 8 9 10

- 1.SERIES NO. 831
- 2.TYPE. A=STANDARD
- 3.CONTACT NUMBER. 03-32
- 4.CONTACT TYPE. P=ZIF
- 5.CONTACT PLATING. T=TIN/LEAD
- 6.MOUNTING TYPE. S=STRAIGHT
- 7.PARTS DIMENSION. 2=PITCH1.25mm
- 8.FILL IT WITH '0'
- 9.FILL IT WITH '0'
- 10.INSULATOR LCOLOR 5=BEIGE

A = 1.25 \* No. of Spaces  
B = A + 7.1  
C = A + 2.7  
\* Available in 3 through 32 circuits

UNLESS OTHERWISE SPECIFIED TOLERANCE		 <b>CHANT SINCERE CO., LTD</b> TEL:886-02-86471251 FAX:886-02-86472962	
ANG.	±5°		
0.	±0.5		
.0	±0.3		
.00	±0.2		
SCALE: AS SHOWN	UNIT: mm		
DRAWN	JOE	01/10/02	DRAWN NAME:
CHECKED	Peal	01/11/02	FPC (1.25mm) ASS'Y(STRAIGHT)
APPROVED	Beke	01/14/02	PRODUCT NO. 831A-XXPTS2005
DATE	01/09/02		FILE NAME: 831A-XXPTS2005(23)

REV.	A	DRA-0201020(Alex)	DESCRIPTION	DATE
------	---	-------------------	-------------	------